

# LABEL-FREE DETECTION OF DNA AMPLIFICATION IN DROPLETS USING ELECTRICAL IMPEDANCE

Melinda G. Simon\*<sup>1</sup>, Robert Lin\*<sup>1</sup>, Javier Lopez-Prieto<sup>1</sup>, Abraham P. Lee<sup>1</sup>

*\*these authors contributed equally to this work*

<sup>1</sup>Department of Biomedical Engineering, University of California - Irvine, USA

## ABSTRACT

Droplets containing DNA amplified through PCR were reliably distinguished from those containing DNA that had not been amplified, using the technique of electrical impedance spectroscopy. The system uses a set of 3 planar electrodes, integrated into a microfluidic device, to measure the impedance of passing droplets and determine whether or not PCR was successfully performed in the droplet. This system has the potential to replace other methods of PCR detection, including fluorescence, with the potential for real-time detection of DNA amplification without the need for labeled substrates.

KEYWORDS: impedance, droplet, PCR, polymerase chain reaction, label-free

## INTRODUCTION

Polymerase chain reaction (PCR) has long been the gold standard in the detection of nucleic acid targets due to the technique's sensitivity and accuracy. Droplet microfluidics' ability to rapidly generate isolated reaction chambers serves as a convenient platform for the adaptation of PCR [1]. Because of the synergy, droplet-based PCR or digital PCR has garnered much research interest in recent years [2, 3]. However, the detection of amplicons traditionally relies on fluorescent probes. The need for fluorescent illumination as well as detection and the processing required to prepare fluorescent markers greatly increases the cost of such systems.

Here we present a novel method to verify the completion of the reaction utilizing impedance-based detection. Incorporating an electrical detection scheme instead of optical, we believe, opens up the possibility of significantly reducing the cost of detecting nucleic acid targets as well as automating the detection process. The process developed herein is able to reliably distinguish between droplets in which PCR amplification occurred and droplets in which it did not. The system presented has the potential to become part of a high throughput integrated microfluidic platform that is capable of performing label-free nucleic acid detection at high rates. Figure 1 illustrates the concept of such a digital PCR system with integrated, impedance-based detection of amplification in droplets.

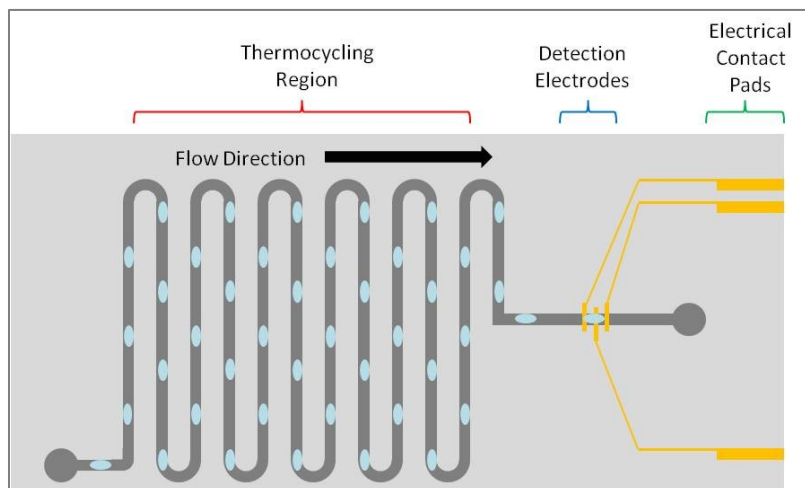

Figure 1 Conceptual schematic of impedance-based detection scheme integrated into a hypothetical droplet-based PCR platform.

## EXPERIMENTAL

During device operation, droplets with and without amplified DNA were flowed over a set of 3 gold electrodes within a microfluidic device. (Figure 2a) A series of droplets were flown through the device and interrogated at four different frequencies. (Figure 2b) Differential impedance measurements across the first two electrodes and second two electrodes were performed using a multi-frequency interrogation scheme and subsequent demodulation. Excitation signal generation, amplification and demodulation were achieved using HF2IS and HF2TA from Zurich Instruments. Typical results obtained

from two droplets are shown in Figure 2c. The peak-to-peak heights of the signals were extracted and significant differences can be observed when comparing droplets with amplified DNA and those without. The difference in voltage signal obtained from these two different populations of droplets is likely due to a change in the solutions' electrical properties resulting from the polymerization reactions.

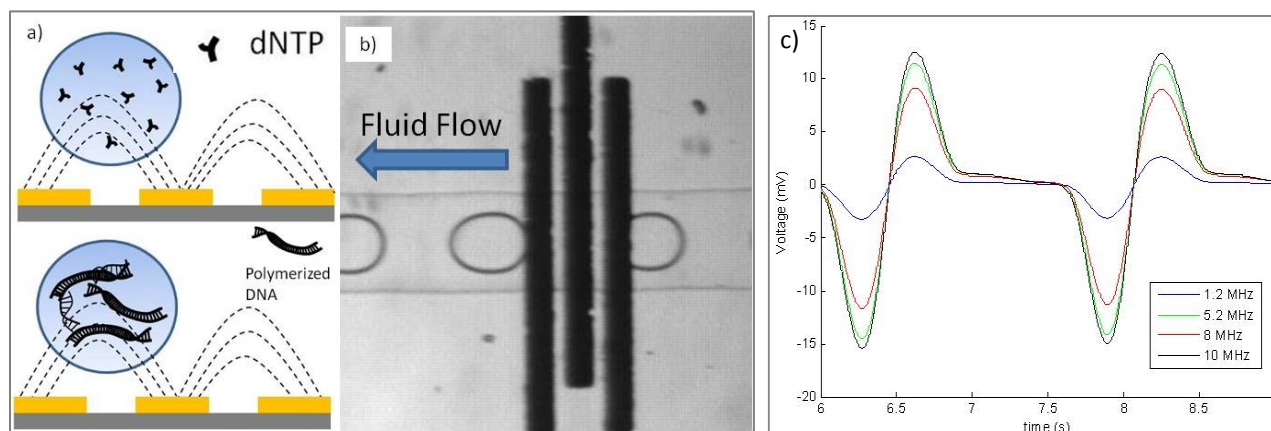

Figure 2 a) Schematic of droplets containing unpolymersed and polymerized nucleic acid monomers. b) Photo of droplets flowing over the detection electrodes. Black rectangles running vertically are the electrodes. c.) Sample plot of 4 frequency measurement data from two consecutive droplets. It can be seen that at difference frequencies the measured voltages are different and these differences can be used to help distinguish droplets of different contents.

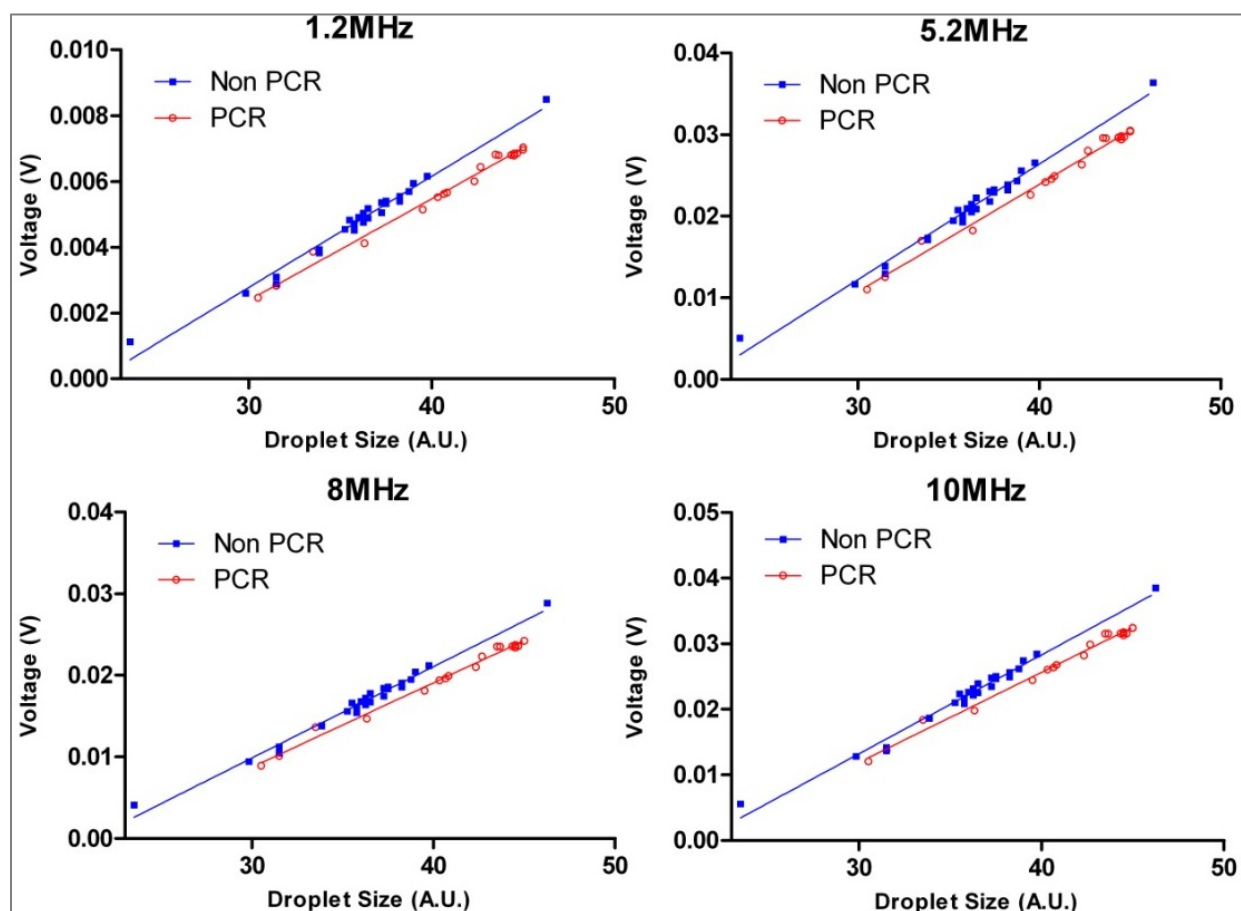

Figure 3. The peak-to-peak voltage obtained for droplets of a variety of sizes shows a difference in the voltage signal obtained from droplets containing amplified DNA (red data points) and non-amplified DNA (blue data points).

points). Each data point represents a single droplet. Difference between PCR and non-PCR sets is significant ( $p < 0.01$ ) by ANCOVA.

## RESULTS AND DISCUSSION

A reference set of droplets were used to create standard curves correlating droplet sizes with the measured voltages. As can be seen from Figure 3, significant differences exist between the thermocycled and non-thermocycled data sets. We test the ability of this platform to be used as a detection tool by using the obtained linear fits as reference curves. A separate set of thermocycled and non-thermocycled droplets was flowed over the electrodes and their size and voltage measurements were recorded. The size data was input into the reference curves and an expected voltage was obtained for both thermocycled and non-thermocycled curves. These values were compared to the measured voltages and the magnitude of the difference between the measured and calculated values was used as the predictor. The result of this is reported in Table 1. It can be seen that when three frequencies were used in conjunction extremely high accuracies can be achieved.

Future work will involve the design of devices to remove the dependency of the voltage signal on the size of the droplet. This will allow for real-time determination of the amplification of DNA in the droplets.

*Table 1 Using the reference curves in figure 3 as a predictor for amplification in a separate set of droplets, a high prediction accuracy can be achieved. Combining data from multiple frequencies provides enhanced discriminatory power in detecting droplets containing either unpolymerized nucleotides or polymerized DNA.*

	% correct, DNA amplified	% correct, DNA not amplified
Frequency 1	94.7	100
Frequency 2	94.7	100
Frequency 3	94.7	100
Frequency 4	94.7	100
Freq 1 + Freq 2 + Freq 4	100	100

## CONCLUSION

Electrical impedance was used to distinguish droplets containing DNA, amplified through PCR, from those containing DNA that had not been amplified. This technique provides a label-free scheme for detection of the success of PCR that may be easily integrated into a microfluidic device containing a module for conducting PCR.

## ACKNOWLEDGEMENTS

This work was supported in part by the Defense Advanced Research Projects Agency (DARPA) N/MEMS S&T Fundamentals Program under grant no. N66001-1-4003 issued by the Space and Naval Warfare Systems Center Pacific (SPAWAR) to the Micro/nano Fluidics Fundamentals Focus (MF3) Center. The authors also acknowledge financial support from Pioneer Hi-Bred International, Inc., and the NSF-IGERT LifeChips program.

## CONTACT

\* A.P. Lee, tel: +1-949-824-9691; aplee@uci.edu

## REFERENCES

1. Teh S, Lin R, Hung L, Lee A: Droplet microfluidics. *Lab on a Chip* 2008, 8:198-220.
2. Zhang Y, Ozdemir P: Microfluidic DNA amplification--A review. *Analytica chimica acta* 2009, 638:115-125.
3. Kiss MM, Ortoleva-Donnelly L, Beer NR, Warner J, Bailey CG, Colston BW, Rothberg JM, Link DR, Leamon JH: High-throughput quantitative polymerase chain reaction in picoliter droplets. *Analytical chemistry* 2008, 80:8975-8981.